



MOTOR OPERATING MECHANISM

MM

MECHANICAL PARTS

The motor operating mechanism is made by two reductions screws-worm wheel, this part lubricated with special grease during the factory assembly don't need maintenance during the service life. It can be operated by motors in AC and DC current.

ELECTRICAL PARTS

All the electrical parts (motor, local remote selector switch, closing/opening push button, motor protection, auxiliary contacts device etc.) assembled on motor operating mechanism are provided by components from industry leaders.

MANUAL OPERATION

With the front door open, it's possible and easily operate manually the disconnecter for emergency by a crank present inside the motor operating mechanism box. Safety operation is ensured with an electromechanical interlocking who does not allow to insert the crank during the motor operation and without the substation protection system consent.

BOX: the box are made on galvanized and painted steel, is ensured the IP55.

CUSTOMIZATION

The motor power supply and the number of auxiliary contacts are customizable in accordance of customer specification.

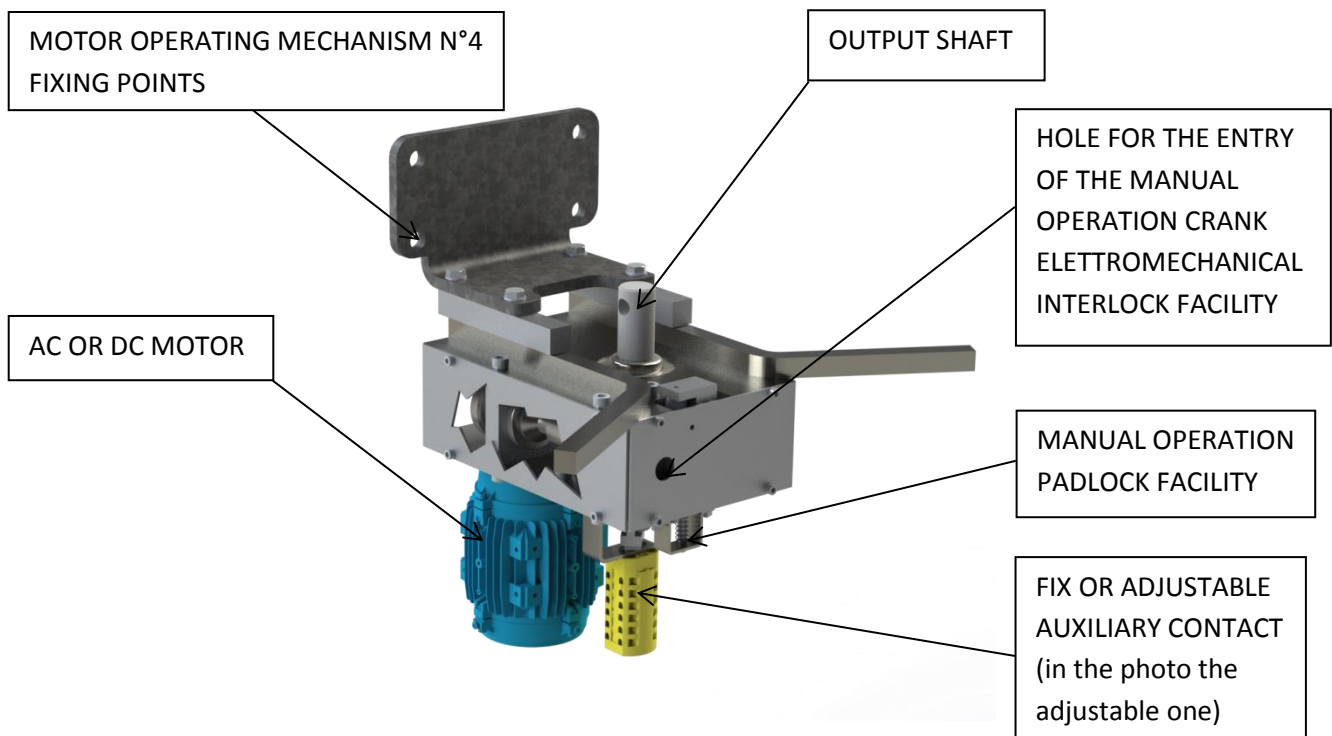

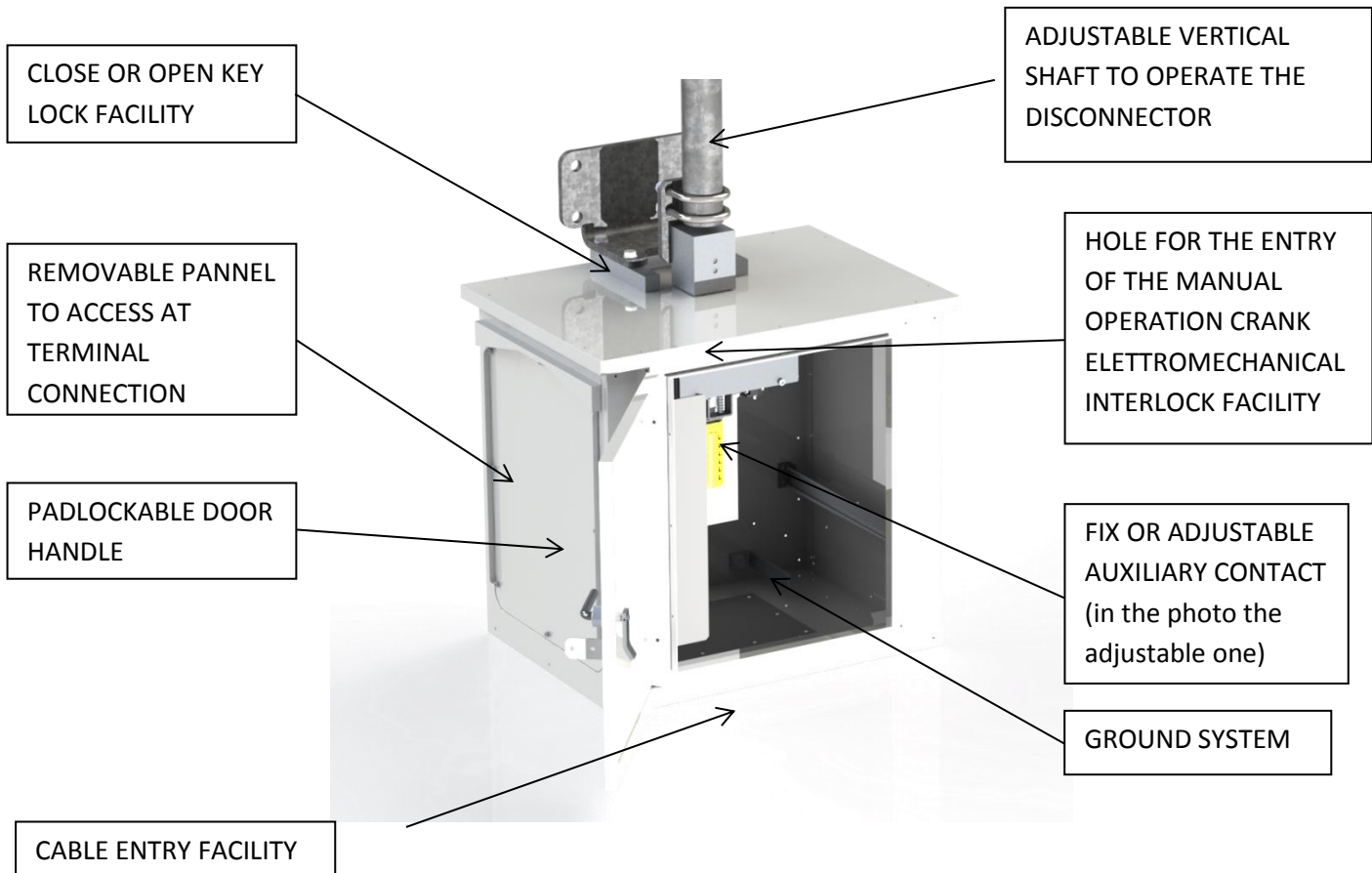

MOTOR OPERATING MECHANISM MM

ADVANCED DESIGN FOR CUSTOMER SATISFACTION

MAIN DIMENSION AND FIXING POINT

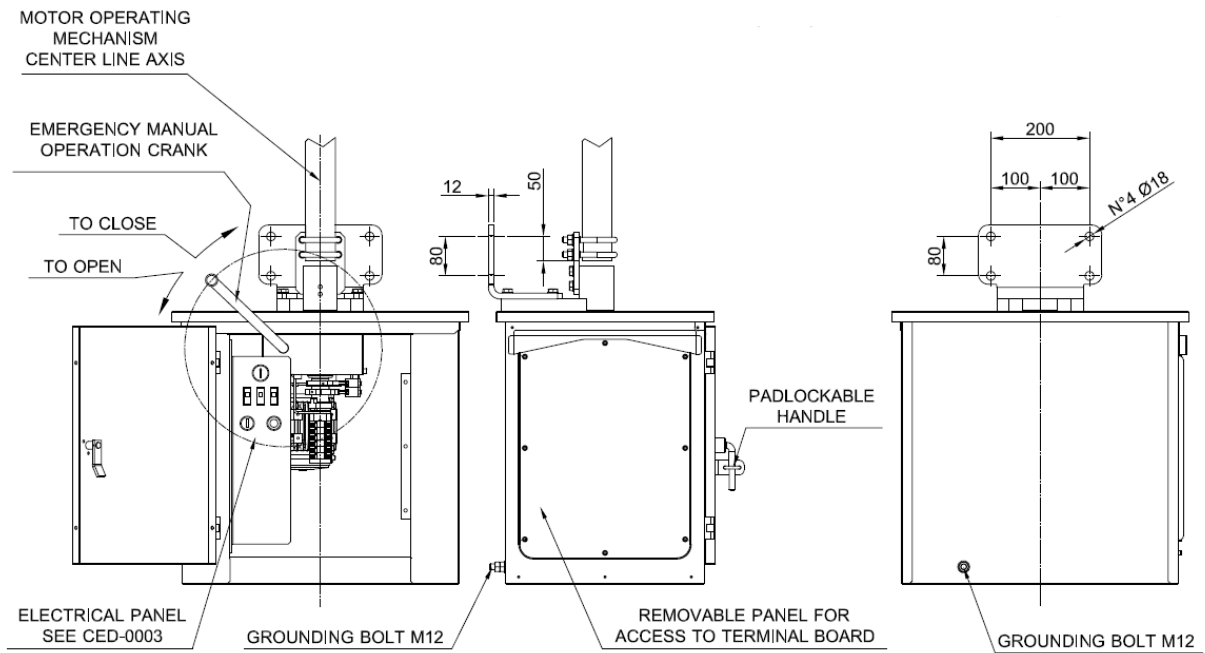

CONTACT US

IDEA45 srl
Via Torino 1/L,
35035 Mestrino (Pd) Italy
Phone: +39 049 856 1274
Fax: +39 049 872 8263
www.idea45srl.com
info@idea45srl.com